

PITUMEC

THE PCON 365 CONCENTRIC UNDERREAMING SYSTEM

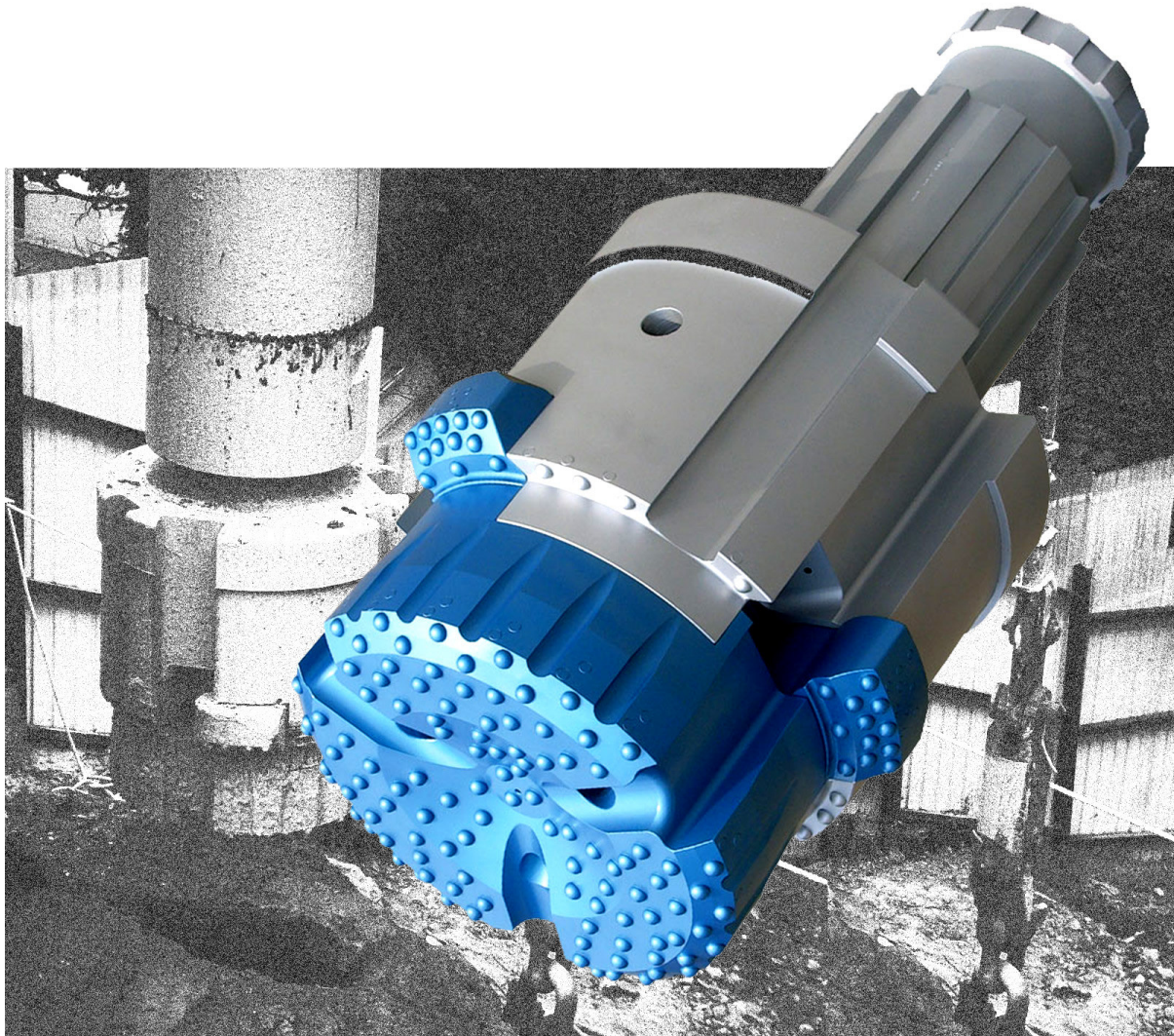

CASING SIZE 406MM OD X 387MM ID DRILLING DIA. 432MM

PNEUMEC PCON 365 CONCENTRIC UNDERREAMING SYSTEM

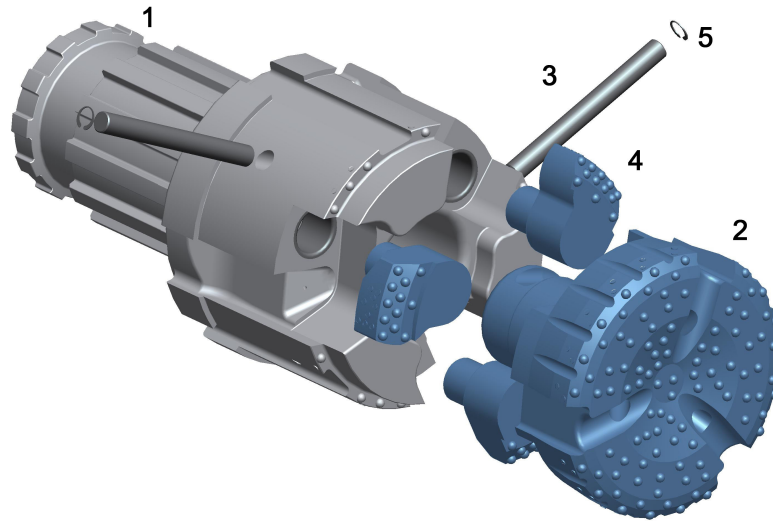

PCON 365 PARTS LIST

1.	GUIDE DEVICE N125 SHANK	UGD365125PCN
2.	PILOT BIT	UPB365PCN
3.	LOCKING PIN (2)	USP36550PCN
4.	REAMER (3)	UBS365PCN
5.	CIRCLIP (2)	USP36553PCN
6.	COMPLETE SYSTEM N125 SHANK	UCS365125PCN

PCON 365 SPECIFICATIONS

UPPER BODY DIAMETER	381MM	CLOSED DIAMETER	365MM
REAMING DIAMETER	457MM	CASING SIZE	406MM OD X 387MM ID
SYSTEM LENGTH	1050MM	SYSTEM WEIGHT	610KG

PCON 365 CASING SHOES

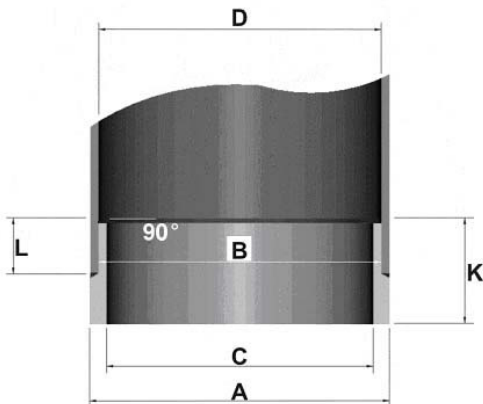

DIA. A	406MM
DIA. B	386.5MM
DIA. C	366.5MM
DIA. D	387MM
L	85MM
K	125MM

PNEUMEC

PNEUMEC COMPANY LIMITED

1st Floor, Tin On Sing Comm. Bldg., 41-43 Graham St. Central, H.K.

Tel : (852) 2180 9922

Fax : (852) 2180 9982

Website : www.pneumec.com

email : info@pneumec.com